

## Suspension Rings

Two-Piece Suspension Rings for Circular Ventilation Ducts

### Product Overview

The suspension ring is designed for the secure suspension and support of circular ventilation ducts in HVAC installations. The ring is manufactured in two halves allowing easy installation around ductwork. The halves are joined using bolts and nuts to create a strong and reliable support connection.

The Anti Vibration version includes a PVC vibration absorbing insert to reduce noise and vibration transmission through the duct support system.

### Key Features

- Two-piece construction for easy installation
- Suitable for spiral and circular duct systems
- Strong mechanical support for suspended ductwork
- Optional PVC vibration absorbing insert
- Compatible with threaded rod suspension systems

### Materials

- Galvanised Steel (standard)



**FRESH AIR  
SUPPLIES**

Product Images / Technical Drawings



For diameters  $\text{Ød1} \leq 400$  mm



For diameters  $\text{Ød1} \geq 450$  mm

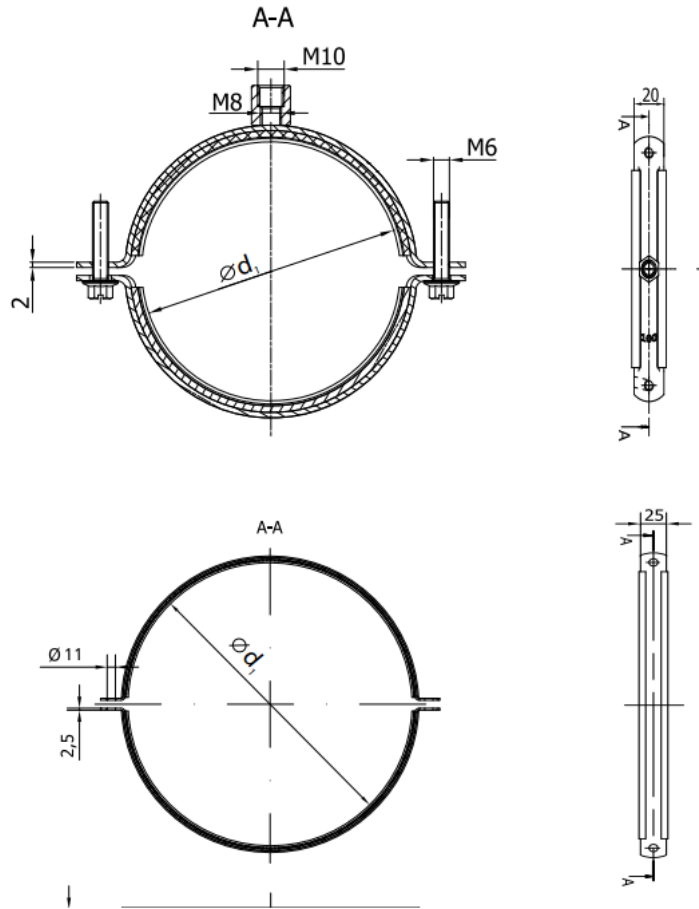

$\varnothing d_{1, nom}$ [mm]	Weight [kg]	$\varnothing d_{1, nom}$ [mm]	Weight [kg]
80	0.2	400	0.5
100	0.2	450	0.6
112	0.2	500	0.6
125	0.2	560	0.7
140	0.2	600	0.7
150	0.2	630	0.8
160	0.2	710	0.9
180	0.3	800	1.1
200	0.3	900	1.2
224	0.3	1000	1.3
250	0.3	1120	1.5
280	0.3	1250	1.6
300	0.4	1400	1.9
315	0.4	1500	2.0
355	0.5	1600	2.2

## Contact

### **Fresh Air Supplies**

**Phone:**

+44 (0) 28 8675 2336

**Email:**

[sales@freshairsupplies.co.uk](mailto:sales@freshairsupplies.co.uk)

**Web:**

[www.freshairsupplies.co.uk](http://www.freshairsupplies.co.uk) | [www.freshairsupplies.ie](http://www.freshairsupplies.ie)



**FRESH AIR  
SUPPLIES**